

ANSWER KEY

HW1: Boolean Algebra

1. **Boolean Simplification:** Draw out the following logic equations without simplifying them first, using 1, 2, or 3-input logic gates.

a. $X = \overline{(AB + CD)}$

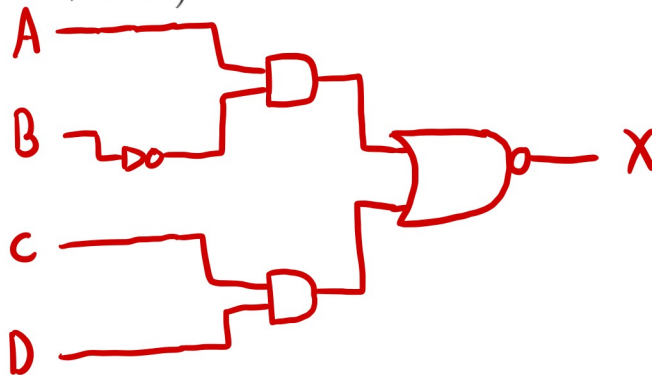

b. $Y = A(B + \overline{CD})$

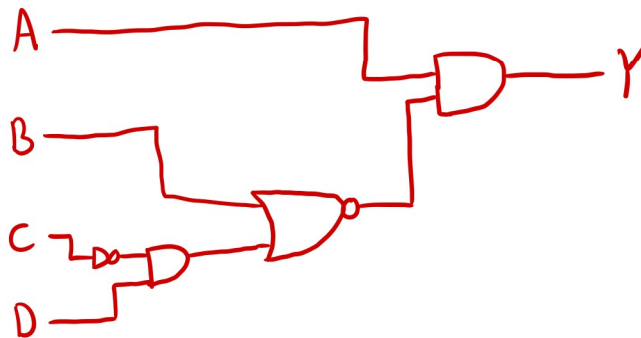

c. $Z = \overline{(A + B)} \cdot \overline{(C + D)}$

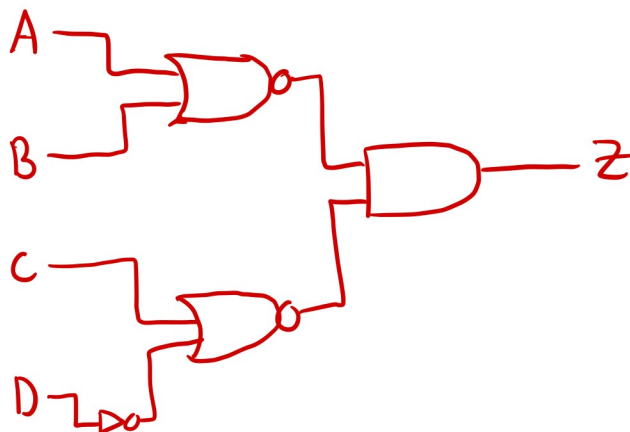

2. **Simplifying Boolean Expressions:** Simplify the following expressions using algebraic manipulation (show steps):

a. $w + (w\bar{x}yz)$

$\equiv w$ from absorption law
 $A + AB = A$
 $B = \bar{x}yz$

b. $xz + \bar{x}y + zy$ Hint: Consensus Theorem

From consensus theorem:
 $ab + \bar{a}c + bc = ab + \bar{a}c$

Thus $xz + \bar{x}y + zy \equiv xz + \bar{x}y$

c. $x[x + (xy)]$

$\equiv xx + xxy$
 $\equiv x + xy$ Idempotent law
 $\equiv x$ Absorption law

d. $(A + C)(\bar{A} + B)(B + C) \equiv \underbrace{A(\bar{A} + B)(B + C)}_{\text{dist.}} + \underbrace{C(\bar{A} + B)(B + C)}_{\text{dist.}}$

$(A\bar{A} + AB)(B + C)$ dist.
 $(0 + AB)(B + C)$ inverse law
 $(AB)(B + C)$ OR identity law
 $ABB + ABC$ dist.
 $AB + ABC$ idempotent
 AB absorption \rightarrow

$(CB + C\bar{C})(\bar{A} + B)$ dist.
 $C(\bar{A} + B)$ idemp. & absorption

$\equiv AB + \bar{A}C + BC$ combine
 $\equiv \boxed{AB + \bar{A}C}$ consensus law

5. Find the equation of the following circuits (do not optimize):

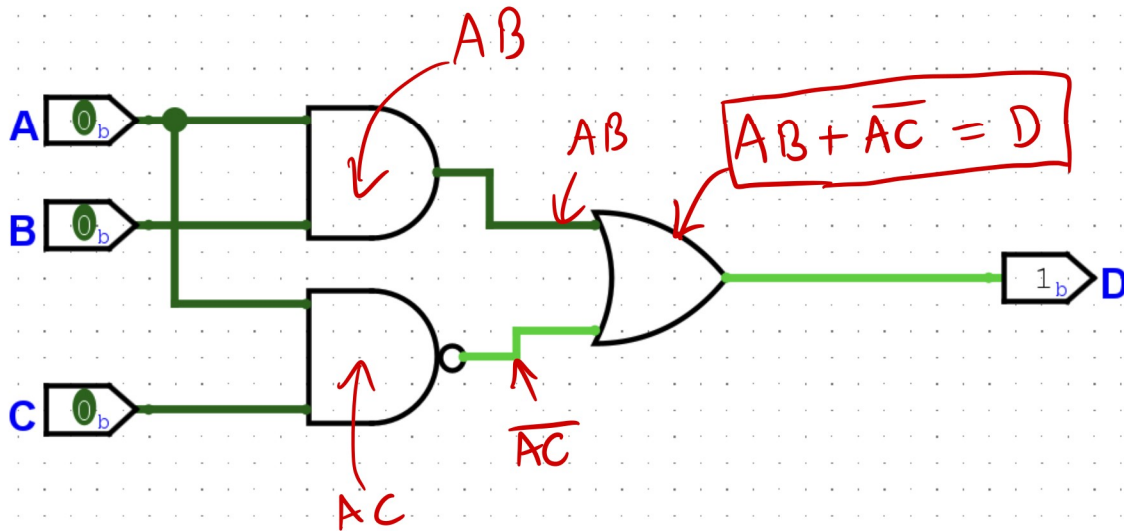

(i) $D(A,B,C) =$

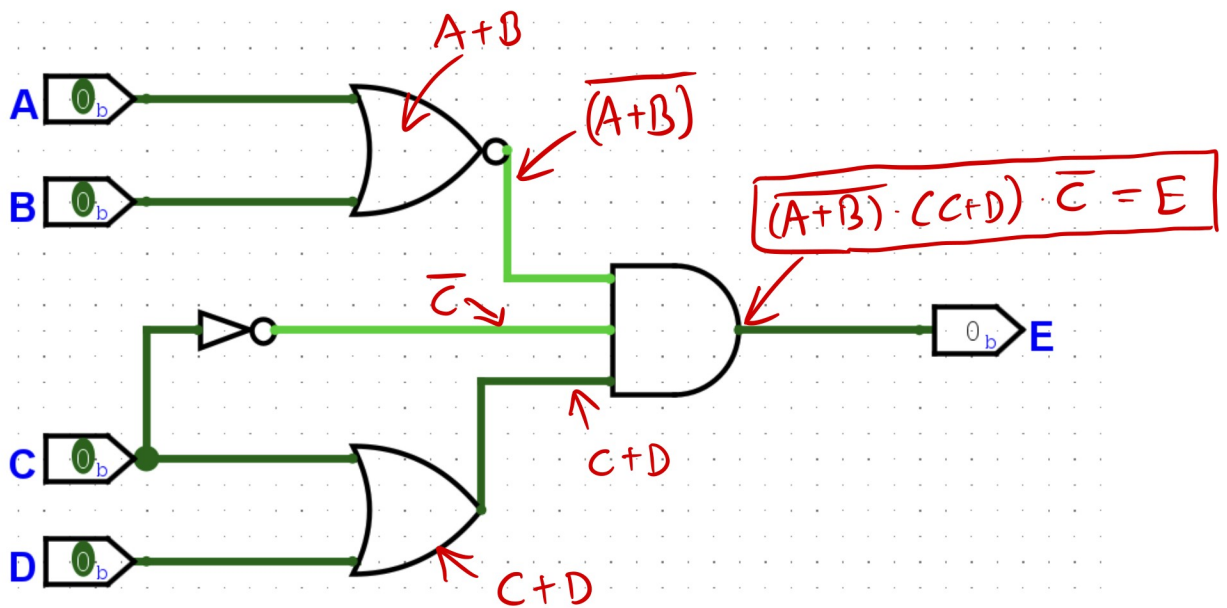

(ii) $E(A,B,C,D) =$