

Digital Logic and Computer Systems

Lecture 0 – Introduction

Dr. Christophe Bobda
EEL3701C Fall 2025

Chapter 0

Introduction, Motivation, Goals

Agenda

1. Syllabus
2. Class Objectives
3. Computing Systems
4. Trends in Computing
5. Research Projects

Syllabus

- Class Information
 - Day and time: MWF 3rd period (09:35-10:25 AM)
 - Location: CSE A101 (face-to-face, automatic recorded and available in Zoom)
 - Students can Zoom in with the proper justification
- Labs: **MAEB222**
- Canvas <https://elearning.ufl.edu/>
- Website: <https://eel3701.ece.ufl.edu/>
 - Slides, Homework, Lab, Tests
 - **Never send homework, labs, exams, per email. Everything must be submitted through either Canvas or GitHub (specified in the assignment)**
- Office Hours: MF, 12:00PM – 1:00 PM
- Announcements, discussion, etc.
 - Slack (Valid until September 13): https://join.slack.com/t/fall2025eel37-dlh8278/shared_invite/zt-3b4emknt3-oYulfsOg5C_DnJQKayyjbw

Grading

Evaluation of Grades

Assignment	Percentage of Final Grade
Laboratory	35%
Homework	10%
Midterm Exam	25%
Final Exam	25%
Attendance	5%
Total	100%

Class Attendance

- iClicker

<https://join.iclicker.com/CIIN>



Syllabus

Grading Policy

Letter	from	to	Points		Letter	from	to	Points
A	93.4	100	4.00		C	73.4	76.6	2.00
A-	90.0	93.3	3.67		C-	70.0	73.3	1.67
B+	86.7	89.9	3.33		D+	66.7	69/9	1.33
B	83.4	86.6	3.00		D	63.4	66.6	1.00
B-	80.0	83.3	2.67		D-	60.0	63.3	0.67
C+	76.7	79.9	2.33		E	0	59.9	0.00

Class Evaluation

- Evaluation is part of the class, and **we expect all students to fill it out**
- It take 10 – 15 minutes to complete your evaluation.
- We put plenty of efforts to prepare and run the class, the minimum if that we receive this feedback
- We understand that you are busy in the evaluation time
 - Time will be allocated to students in class and in labs during the evaluation period
 - Take that opportunity to complete your evaluation.

Labs & Exercises

- Labs
 - Theory: Home preparation
 - Report: Due before lab section
 - Lab: In lab activity or quiz
 - [Guidelines](#)
- Exercises & Homework
 - Preparation: Before exercise session
 - Exercise session: With your PI. Solve problems, answer questions, prepare for exams
 - Graded homework
- Deadline:
 - On deadline: No penalty
 - After deadline: 1 day late with 25% penalty, 0% after

Literature

Charles H. Roth Jr., Larry L Kinney, “Fundamentals of Logic Design”, Publisher : Cengage Learning, Publication date : February 25, 2013, Edition : 7th, ISBN-10 : 1133628478 ISBN-13 : 978-1133628477

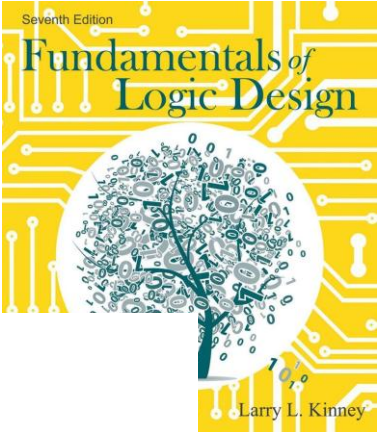

 Andrew Groeling/Brooke Boeding

★★★★★ **Exactly what I hoped**

 July 3, 2019

Format: Paperback | **Verified Purchase**

I was skeptical about the price at first, but it's the real deal. Page for page it matches the more expensive one at the bookstore. The only difference is it's in black and white instead of blue and white. Comes with the same CD too.

Ju |  zahiah salem

Fo |

I u |

is | ★☆☆☆☆ **Wording and explanations are terrible**

pr | September 12, 2018

sti | Format: Hardcover | **Verified Purchase**

th | This book made the ECE lectures even more confusing... it is not helpful at all. regret buying it.

ire a more
a class, and I
book for the

Literature

Computer Organization and Design MIPS Edition: The Hardware/Software Interface (The Morgan Kaufmann Series in Computer Architecture and Design)
by David A. Patterson, John L. Hennessy,
ISBN-13: 978-0124077263

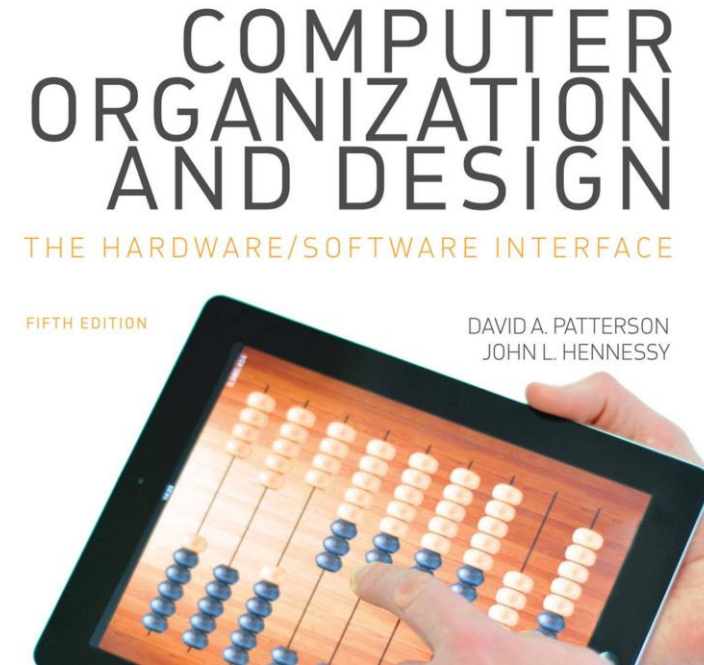

<https://www.elsevier.com/books/computer-organization-and-design-mips-edition/patterson/978-0-12-407726-3>

ID	Date	Software Type	Software Package	Version	Operating Systems
849770	3/17/2025	FPGA Development Tools	Quartus® Prime Lite	24.1 (Latest)	Windows

Lab Platform

- Intel DE-10 Lite FPGA board
- Inventory management
 - Check-out through a quiz
 - Return at the end of the semester
 - **No final grade if a board is not turned-in**

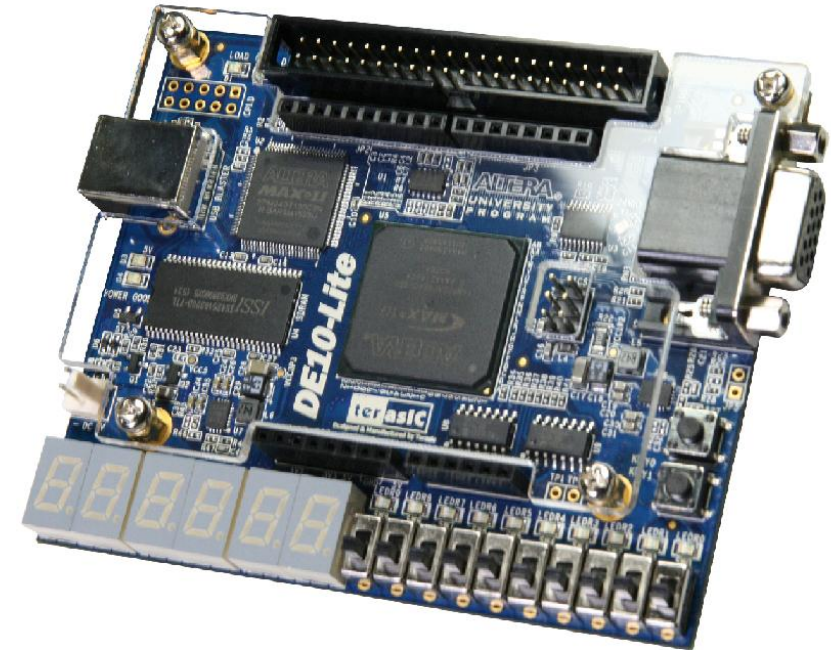

Teaching & Learning Flow

Student & Instructors' Responsibilities

- Helping Students to Succeed
 - Introduce,
 - Explain,
 - Reinforce,
 - Test

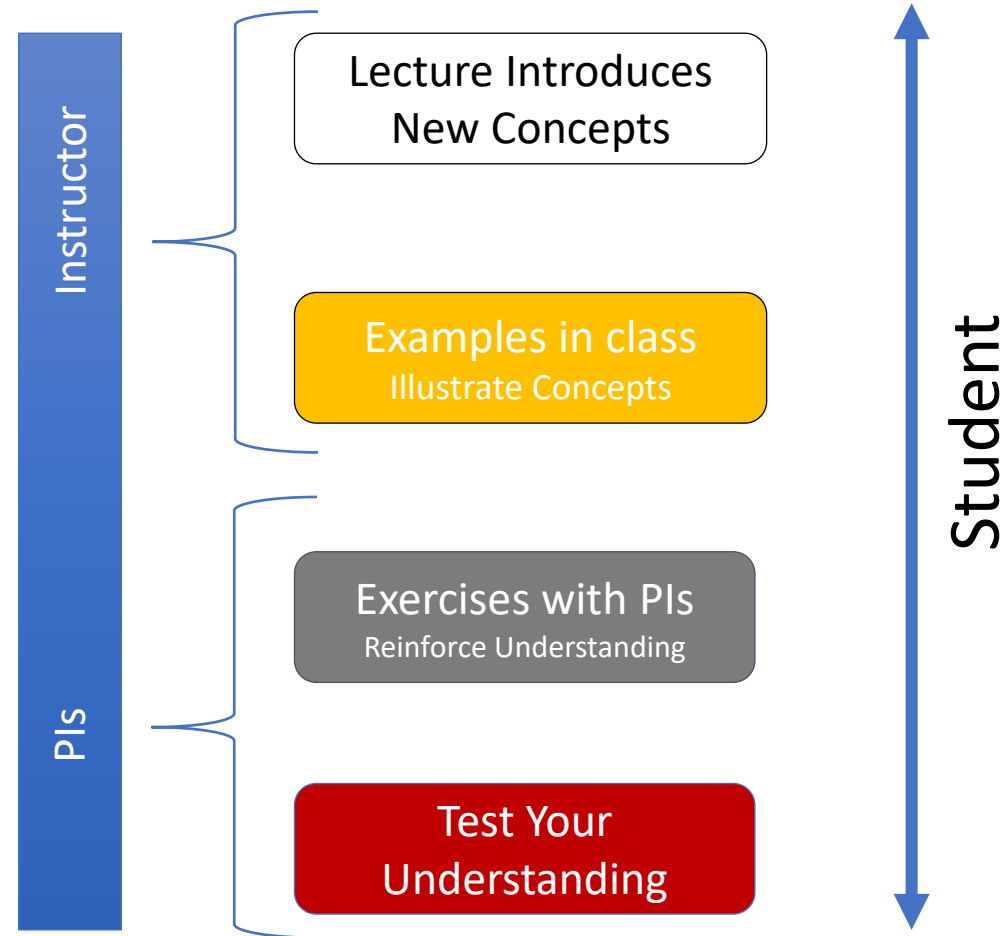

Learning & Learning Flow

Student & Instructors' Responsibilities

- Follow me in class
- After class, go over the slides again
- Try to do the examples again and make sure you understand
- Mark what you don't understand and formulate questions
 - Ask your question per email/chat
 - Go to instructor/PI office hours

Semester Schedule

■ Introduction		
■ Gate-Level Models	}	2 Weeks
■ Number Systems		
■ Design of Combinational Circuits	}	2 Weeks
■ RTL Components		
■ Sequential Circuits		1 Week
■ Automata/Finite State Machines		1 Week
■ Register-Transfer-Level/Microarchitecture		2 Week
■ Control Path/Single Purpose Processor		1Week
■ MIPS ISA/Assembler Programing		1Week
■ Processor Design		3 Weeks
■ Misc (Programmable Logic, etc...)		

10/14/2025: Midterm

12/10/2025: Final

Semester Schedule

AUGUST

• 2025 •

MON	TUE	WED	THU	FRI	SAT	SUN
•	•	•	•	1	2	3
4	5	6	7	8	9	10
11	12	13	14	15	16	17
18	19	20	21 Classes start	22	23	24
25 Lab 0 and 1 open	26	27 Last day of Add/Drop	28	29	30	31 Pre-lab 0 due

** next labs will be open after previous pre-lab is due

Semester Schedule

SEPTEMBER

• 2025 •

MON	TUE	WED	THU	FRI	SAT	SUN
1 Holiday No School	2 LAB 0	3	4	5	6	7 Pre-lab 1 due
8 HW 1 due LAB 0	9 LAB 1	10	11	12	13	14 Pre-lab 2 due
15 HW 2 due LAB 1	16 LAB 2	17	18	19	20	21 Pre-lab 3 due
22 HW 3 due LAB 2	23 LAB 3	24	25	26	27	28
29 LAB 3	30	•	•	•	•	•

Semester Schedule

OCTOBER

• 2025 •

MON	TUE	WED	THU	FRI	SAT	SUN
•	•	1	2	3	4	5 Pre-lab 4 due
6 HW 4 due	7	8	9	10	11	12
LAB 4						
13	14 Exam 1	15	16	17 Homecoming No School	18	19 Pre-lab 5 due
20 HW 5 due	21	22	23	24	25	26
LAB 5						
27	28	29	30	31	•	•

Semester Schedule

NOVEMBER

• 2025 •

MON	TUE	WED	THU	FRI	SAT	SUN
•	•	•	•	•	1	2 Pre-lab 6 due
3	4	5	6	7	8	9
LAB 6						
10 HW 6 due	11 Holiday No School	12	13	14	15	16 Pre-lab 7 due
17	18	19	20	21	22	23
LAB 7						
24 Holiday No School	25 Holiday No School	26 Holiday No School	27 Holiday No School	28 Holiday No School	29	30

Semester Schedule

DECEMBER

• 2025 •

MON	TUE	WED	THU	FRI	SAT	SUN
1 HW 7 due	2	3	4 Reading Days	5 Reading Days	6	7
8	9	10 Exam 2	11 Freedom!	12	13	14
15	6	17	18	19	20	21
22	3	24	5	26	27	28
29	30	31	•	•	•	•

Class Objectives

- To learn the fundamentals of logic design and optimization
 - Design and optimization of combinational and sequential circuits
 - Understand the components of register transfer and their application in computer design
- To understand the organization and operation of existing computing systems
 - Instruction Set Architectures (ISA)
 - Design and optimize general purpose processors

Class Objectives

- Introduction
- Binary Number and Binary Codes
- Gate-Level Models
- Design of Combinational Circuits
- Design of Sequential Circuits
- Register-Transfer-Level/Microarchitecture
- Assembler Programming
- Processor Design
- Implementation/Technology

Computer Systems



Laptop/Workstation



Smart phone PDA



Cars



Wearable



Datacenter

Gaming



Appliance

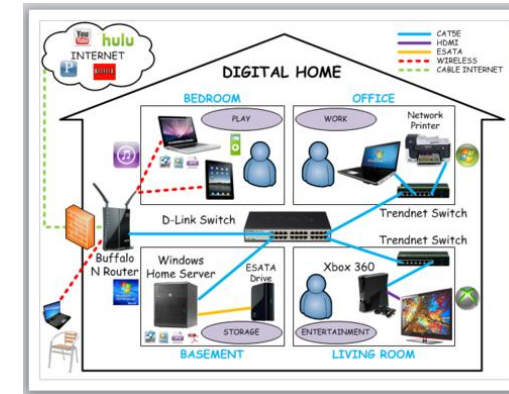

Home Networking IOT



Infotainment



SCADA



Communications



Medical

Computer Systems

- Explosive Growth in
 - Computation
 - Communication
 - Storage
- Yearly produced
 - Millions of PCs, Laptops, Workstations, Mainframes, Servers
 - Billions of embedded computers (household, cars, planes, medical, etc...)
- Computer Science/Computer Engineering
 - Deals with computer
 - Computer Science → Software ?
 - Computer Engineering → Hardware ?

Computer Layered Model

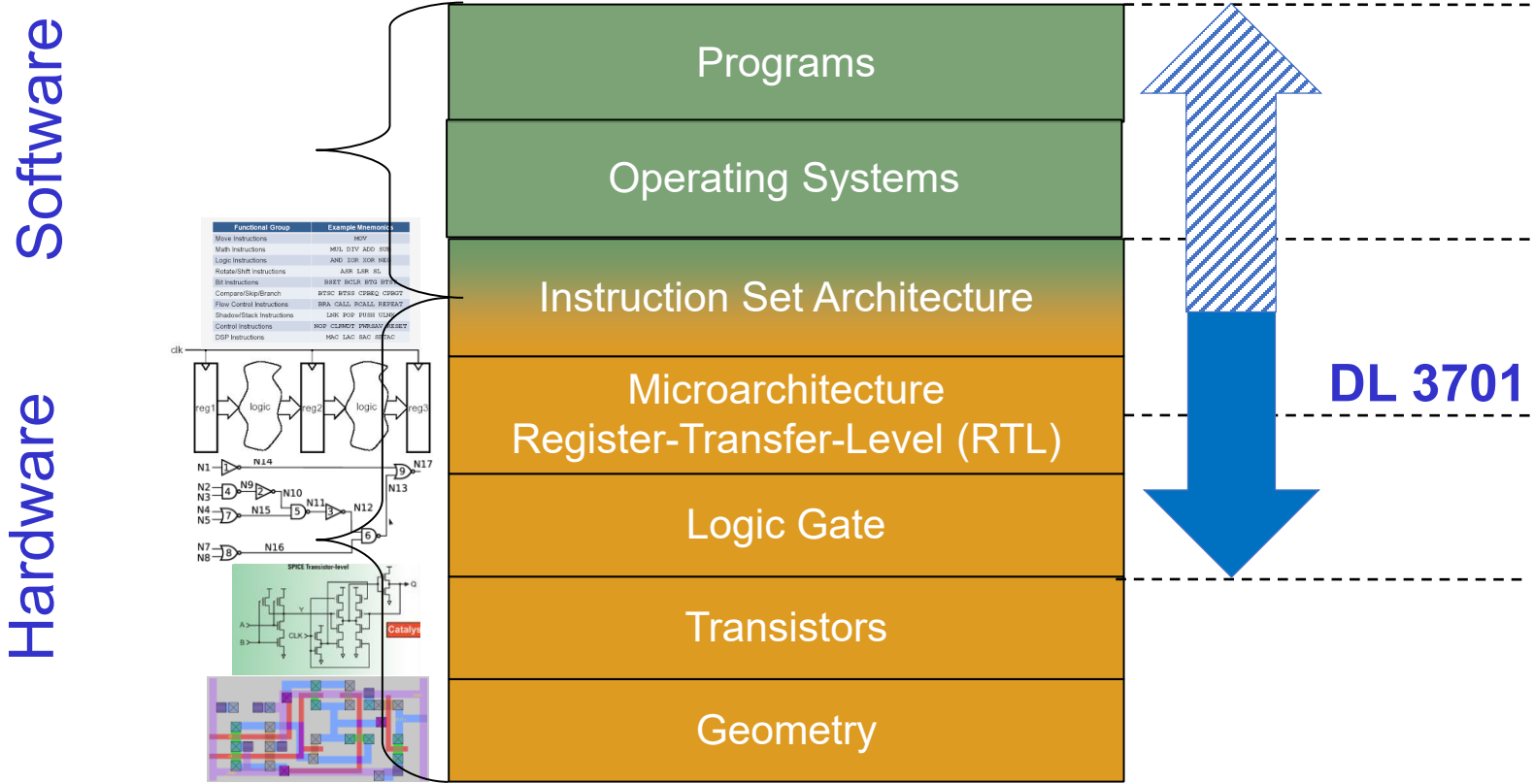

Moore's law forever?

- The most important trend in computer systems
 - Predicted in 1965 by Intel co-founder Gordon Moore
- IC transistor capacity has doubled roughly every 18 months for the past several decades

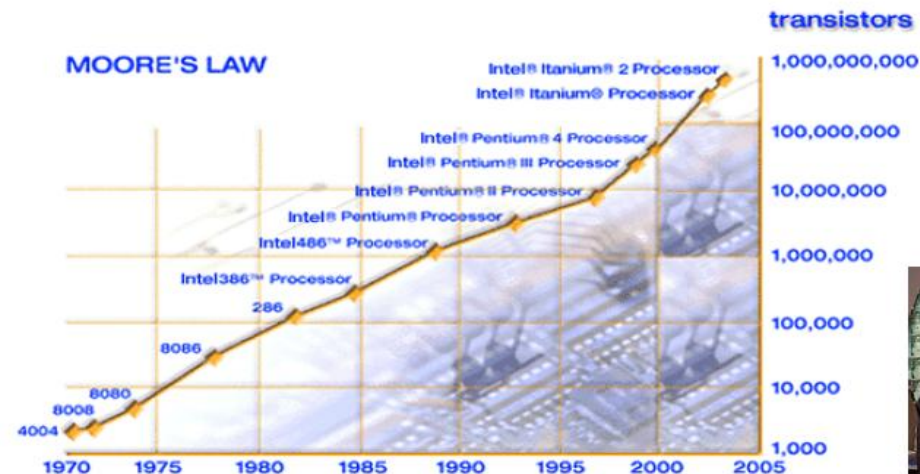

System on Chip

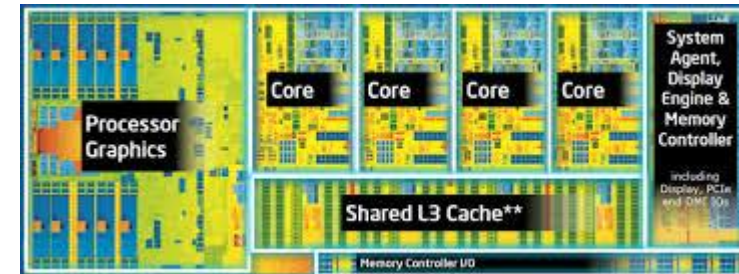
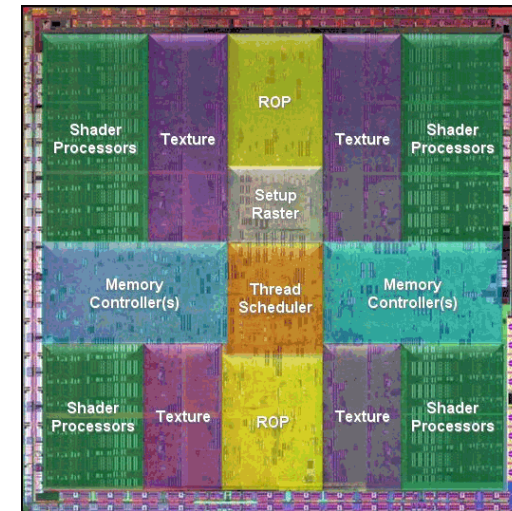
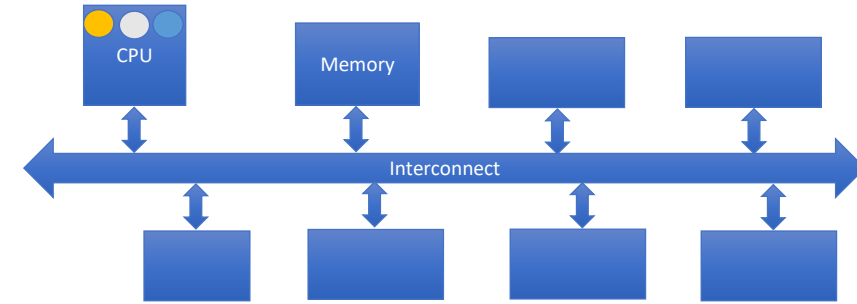

Increasing computational loads

The screenshot displays two news articles. The top article is from The Washington Post, titled "AI chatbots lose money every time you use them. That is a problem." by Will Oremus, dated June 5, 2023. The sub-headline reads: "The cost of operating the systems is so high that companies aren't deploying their best versions to the public." The bottom article is from The Verge, titled "Microsoft spent hundreds of millions of dollars on a ChatGPT supercomputer" by John Koel, dated May 1, 2023. The sub-headline reads: "ChatGPT's Electricity Consumption" and "ChatGPT may have consumed as much electricity as 175,000 people in January 2023." The article is marked as a "Member-only story" and is categorized as "OPINION".

The Washington Post
Democracy Dies in Darkness

AI chatbots lose money every time you use them. That is a problem.

The cost of operating the systems is so high that companies aren't deploying their best versions to the public

By Will Oremus
June 5, 2023 at 6:00 a.m. EDT

FORBES > INNOVATION > CONSUMER TECH

Cha
Day
Mal
Mo

TheVerge / Tech / Reviews / Science / Entertainment / More +

MICROSOFT / TECH / ARTIFICIAL INTELLIGENCE

Microsoft spent hundreds of millions of dollars on a ChatGPT supercomputer

John Koel
Journalist

2

Member-only story

OPINION

ChatGPT's Electricity Consumption

ChatGPT may have consumed as much electricity as 175,000 people in January 2023.

Kasper Groes Albin Ludvigsen · Follow
Published in Towards Data Science · 7 min read · Mar 1

Hardware Accelerators

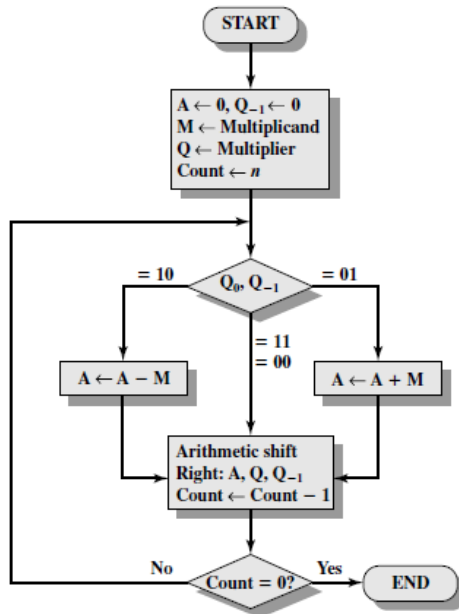
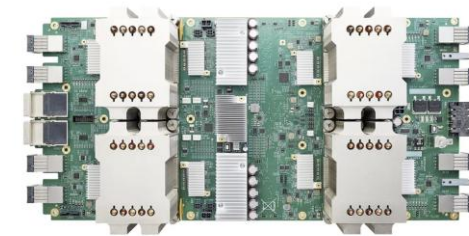
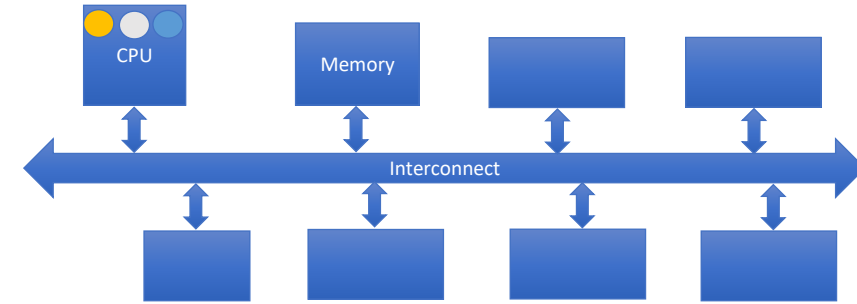

Computer System Research

Distributed Smart Cameras Traffic Light Optimization

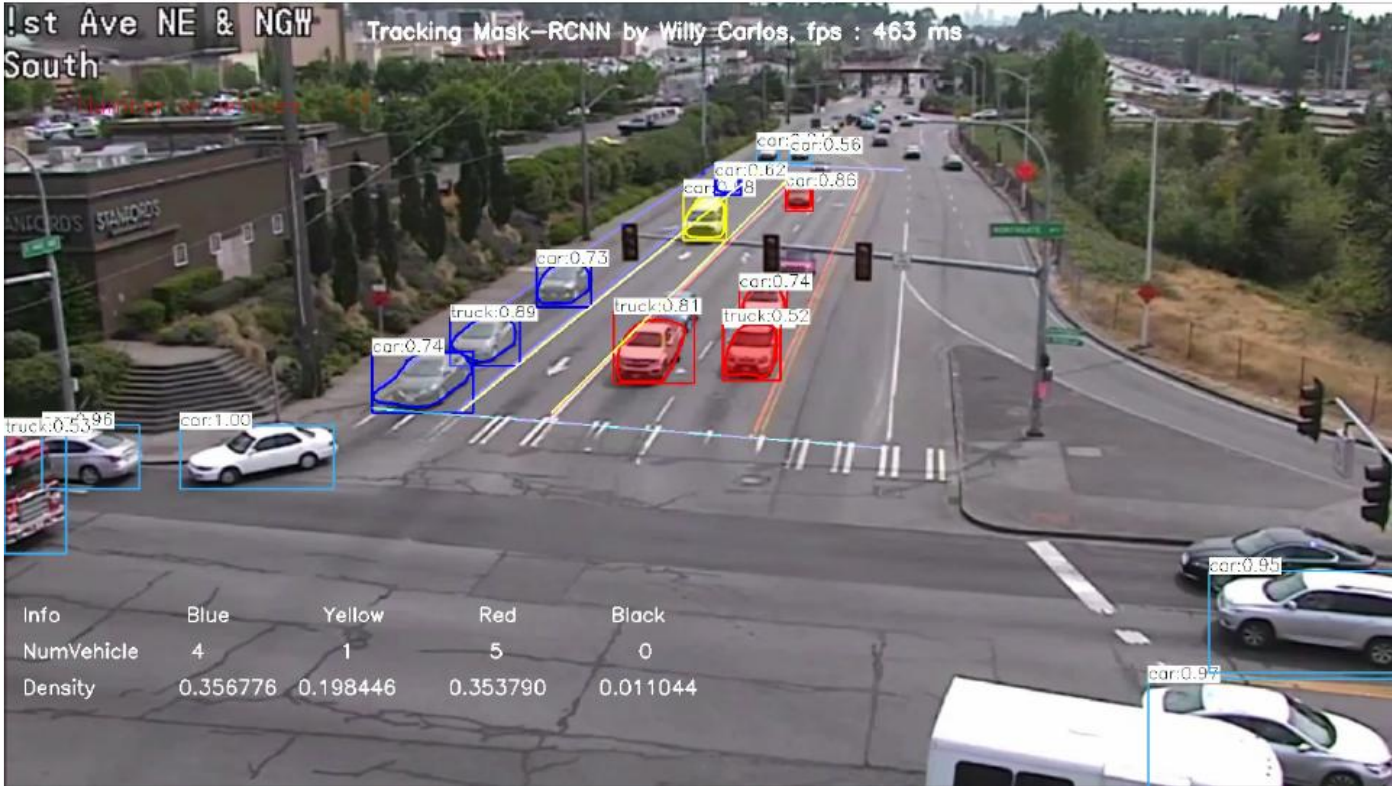

Autonomous Systems

- Vision-based navigation
- Sensor fusion
- Control
- Field analysis
- Security ex. Anti-Jamming

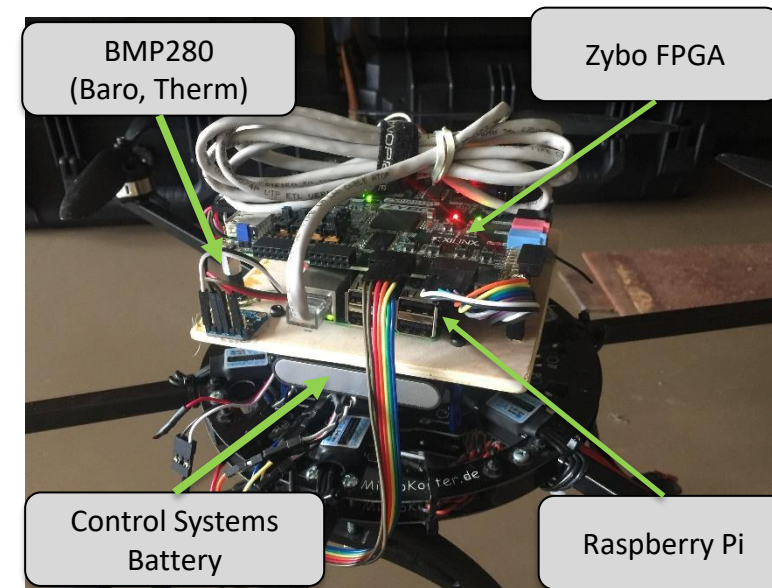
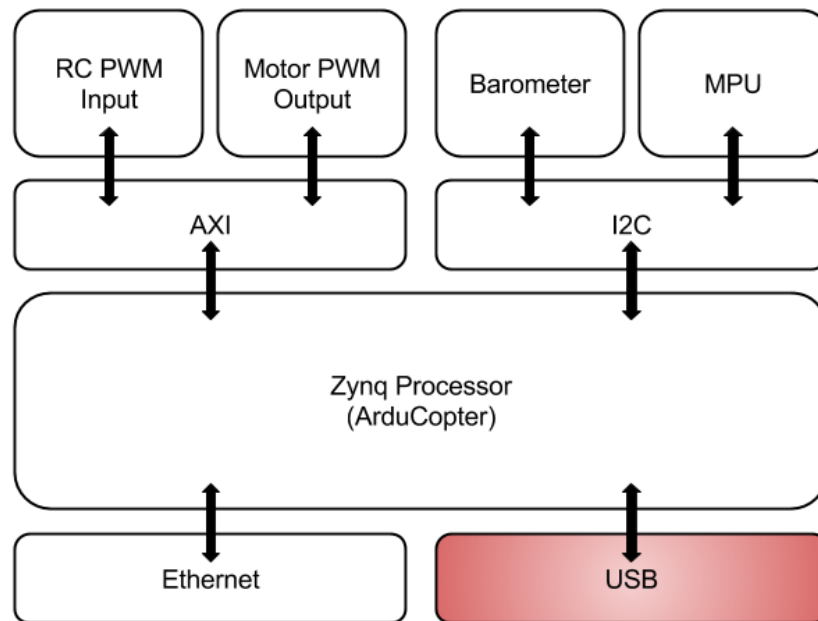

Fall Prevention

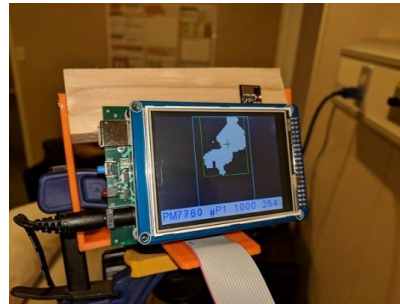
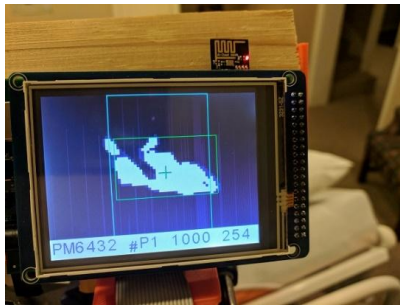
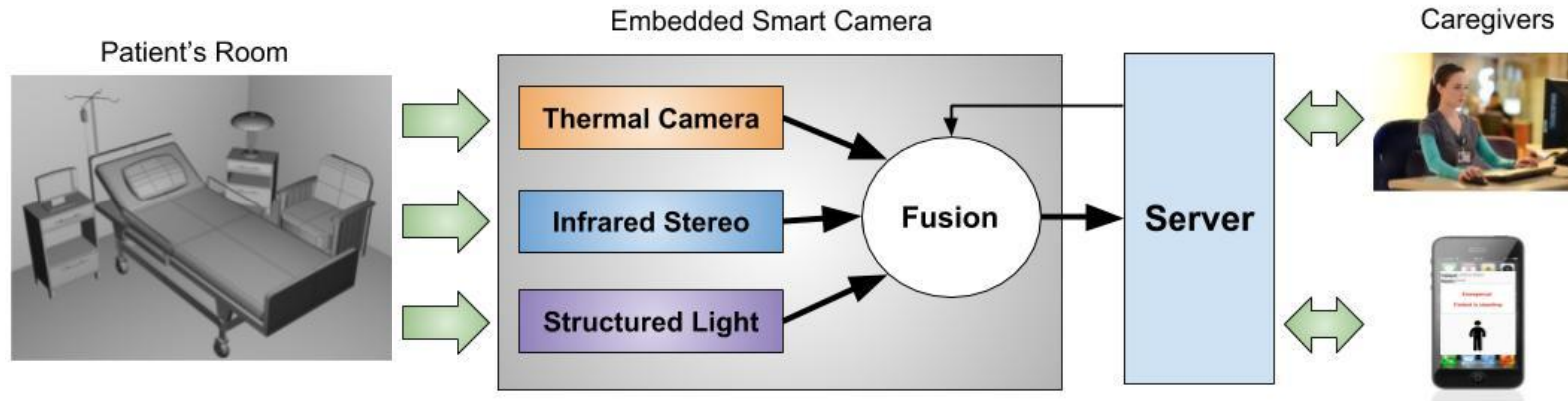

Architecture Diversification in Cloud Computing Systems

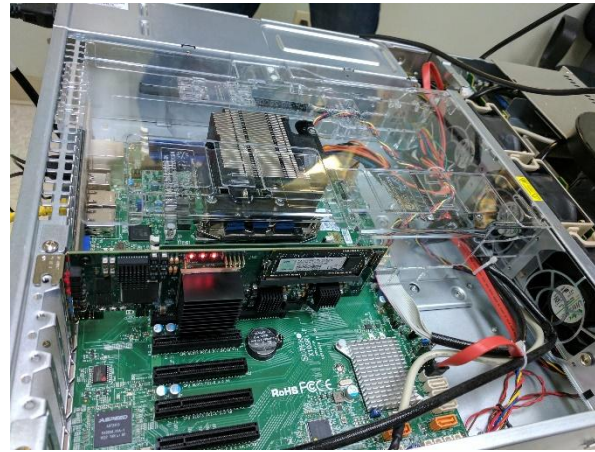

Learning From Nature Bio-Inspired Vision

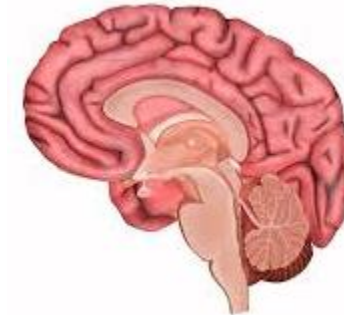
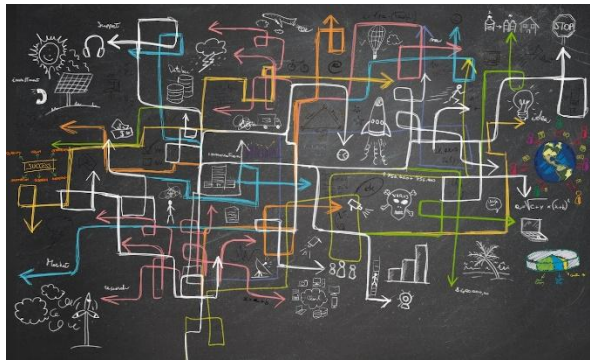
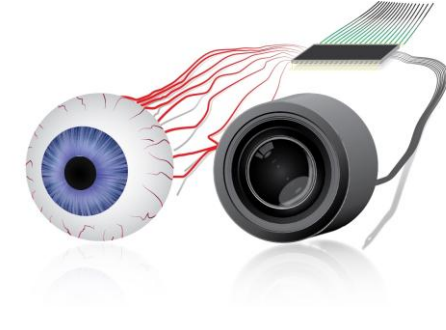

Goal: to leverage new discoveries in neuroscience to guide the design of improved sensing and processing devices.

In turn, we aim to generate new detailed hypotheses for how the brain implements sensory algorithms by exploring various implementations and configurations of devices and architectures.



Health/Elderly/etc.... Care



Virtual/Augmented Reality



Sport Analytics

- Tracking and analyzing free throw trajectories could help assess and improve performance

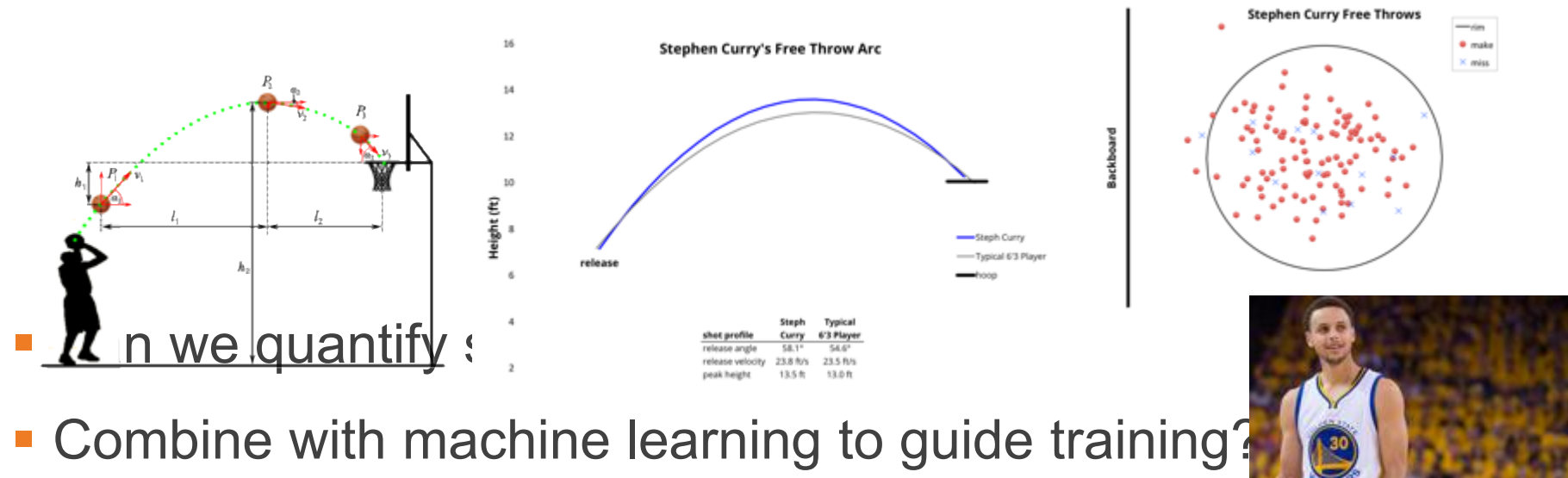

- Can we quantify this?
- Combine with machine learning to guide training?

Let Students Explore The World and Have Fun

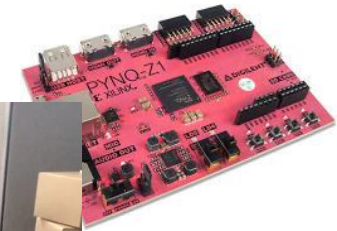
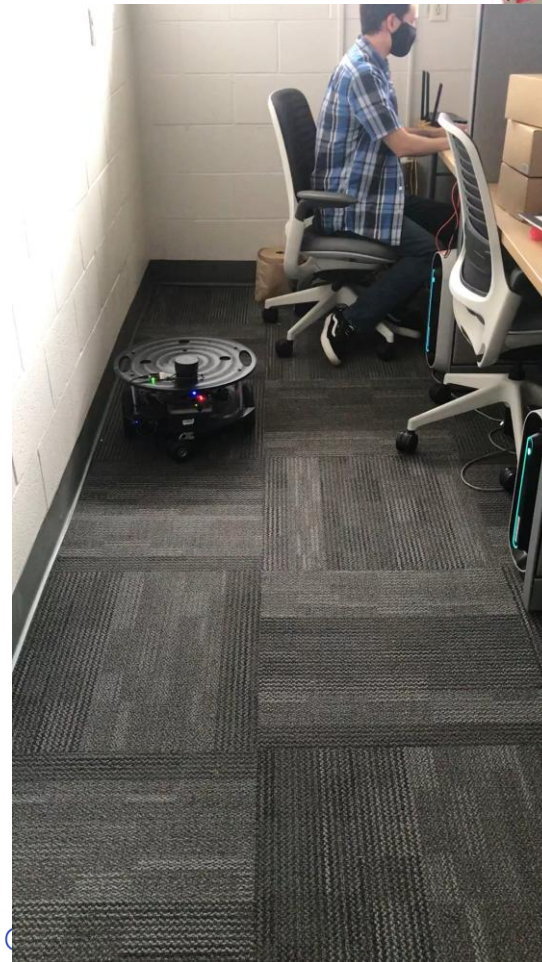
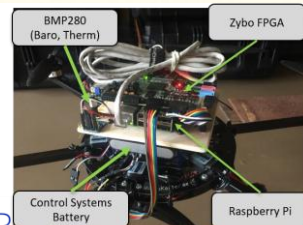
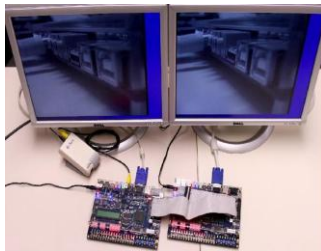
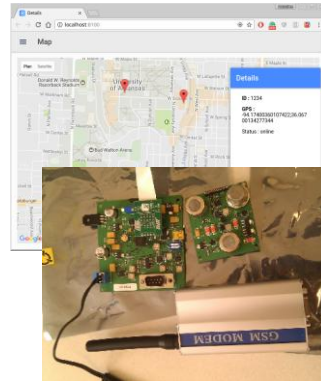

Autonomous Cars

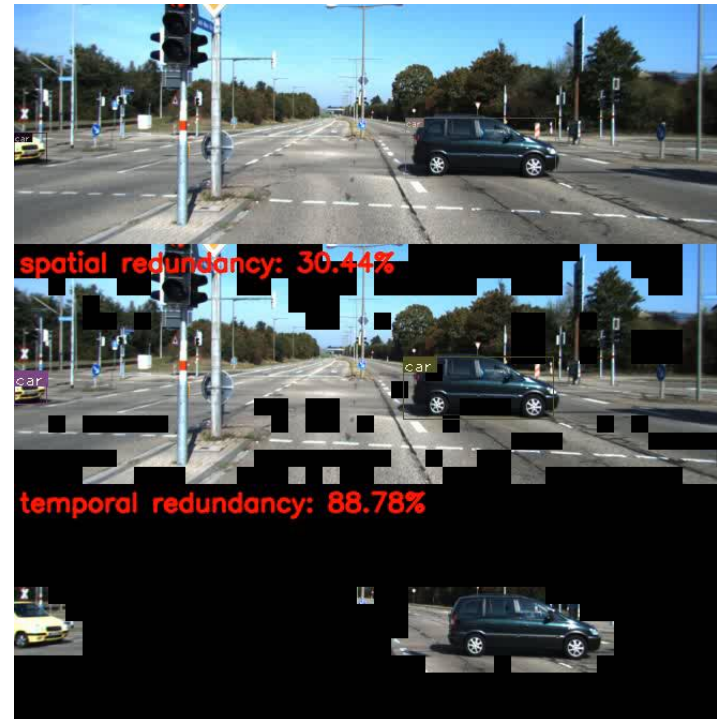
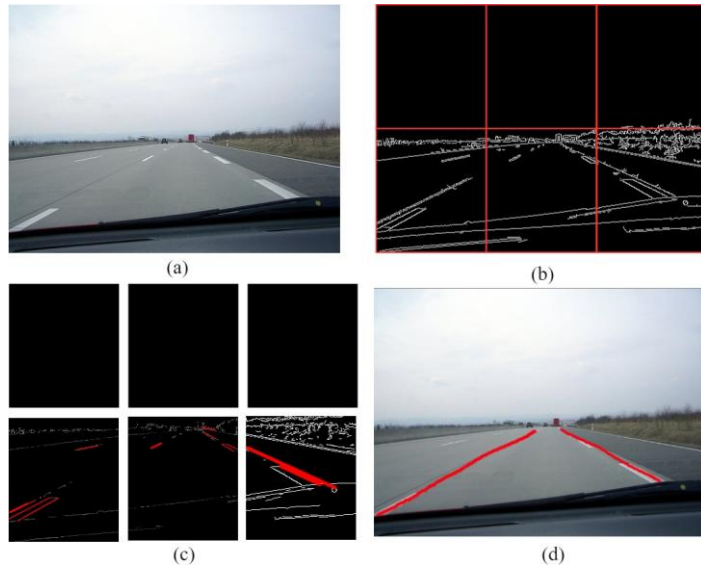

Human Detection/Tracking



Get Involved

- <https://www.ece.ufl.edu/academics/undergraduate/experiential-learning/>



Experiential Learning

The Electrical and Computer Engineering Department is committed to providing our students with exceptional experiential learning opportunities—learning beyond the classroom. Through internships with industry leaders, engaging in cutting-edge research through Research Experiences for Undergraduates (REU) programs, and exploring new horizons through our Study Abroad initiatives, we empower our students to gain hands-on experience, broaden their horizons, and prepare for a successful future in the ever-evolving fields of electrical and computer engineering. [ECE-Experiential Learning Timeline](#)

Internships & Co-Op Experiences



Undergraduate Research



Study Abroad



Pathways to Leadership



Professional Development



Build Something Real





UF | Herbert Wertheim
College of Engineering
UNIVERSITY *of* FLORIDA

LEADING THE CHARGE, CHARGING AHEAD